



Assembly Instructions

Model : BS 8007

Part List		QTY
1	Top Rack	1
2	Upper Middle Rack	1
3	Middle Rack	1
4	Lower Middle Rack	1
5	Lower Rack	1
6	Plinth Panel	5
7	Metal Frame Leg (L)	1
8	Metal Frame Leg (R)	1
9	Metal Support Legs	10

Hardware		QTY
A	Allen Key M4 	1
B	Wood Dowel 	15
C	JCBC Screw M6x50 + M6 Flat Washer 	20
D	CSK Screw M4x32mm 	30
E	CSK Screw M4x50mm 	15

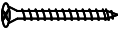
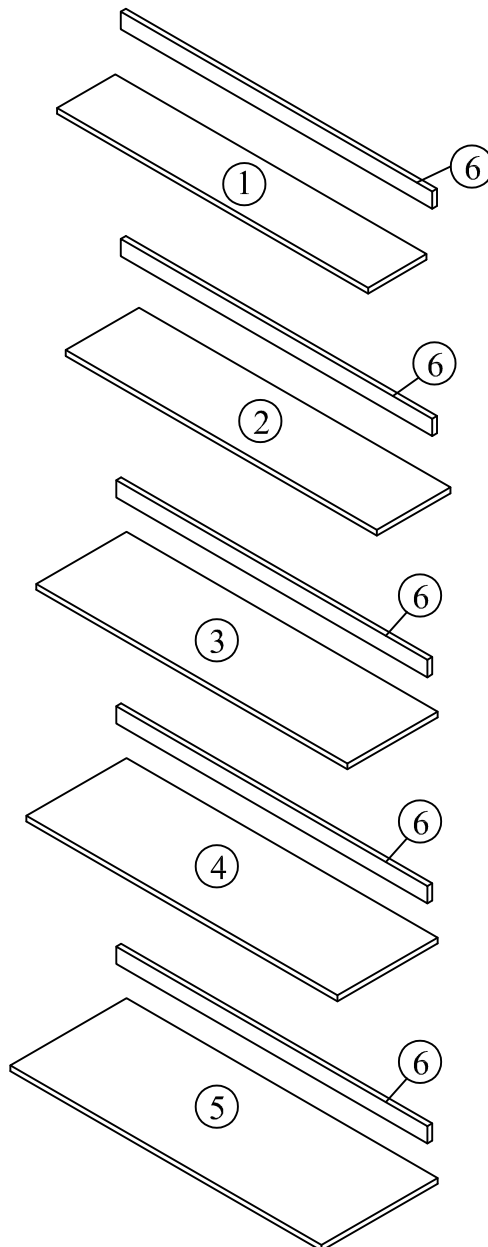
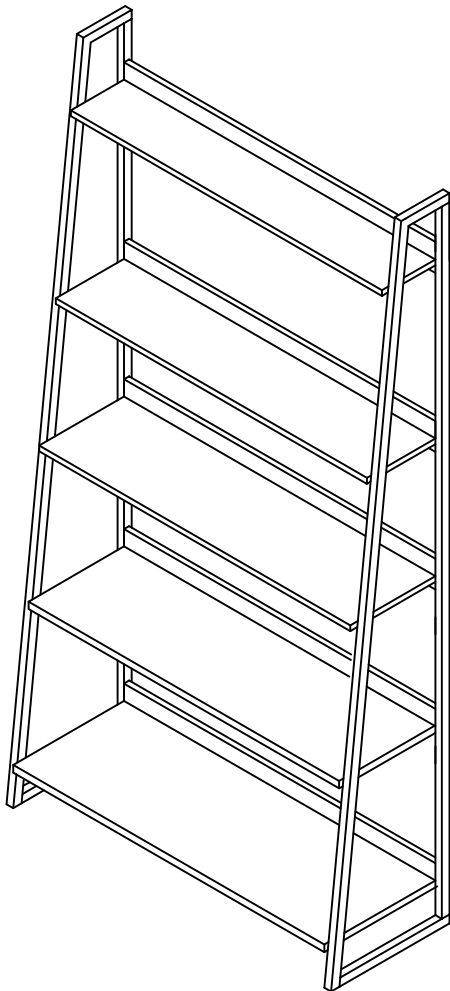

Step 1

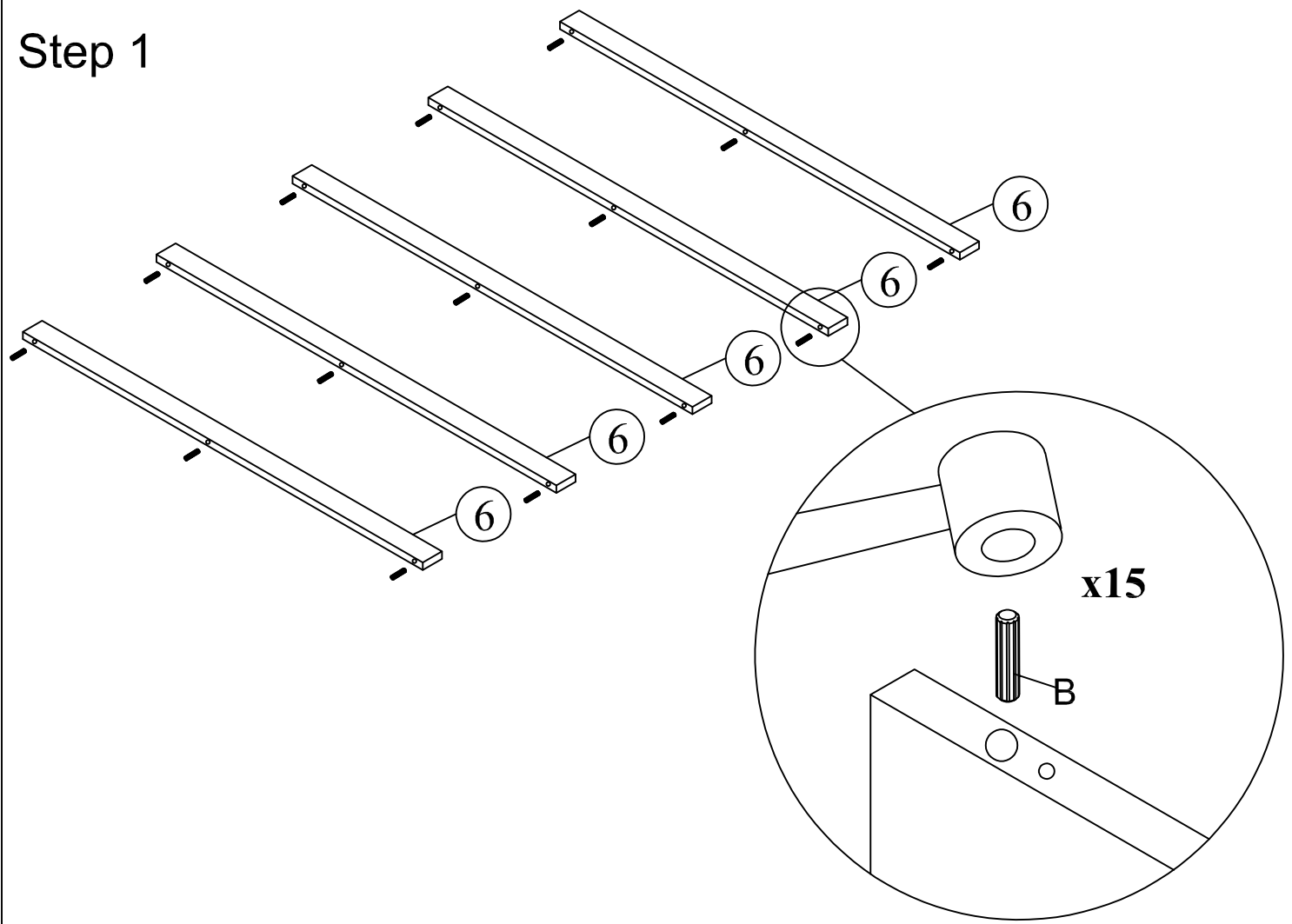

Step 2

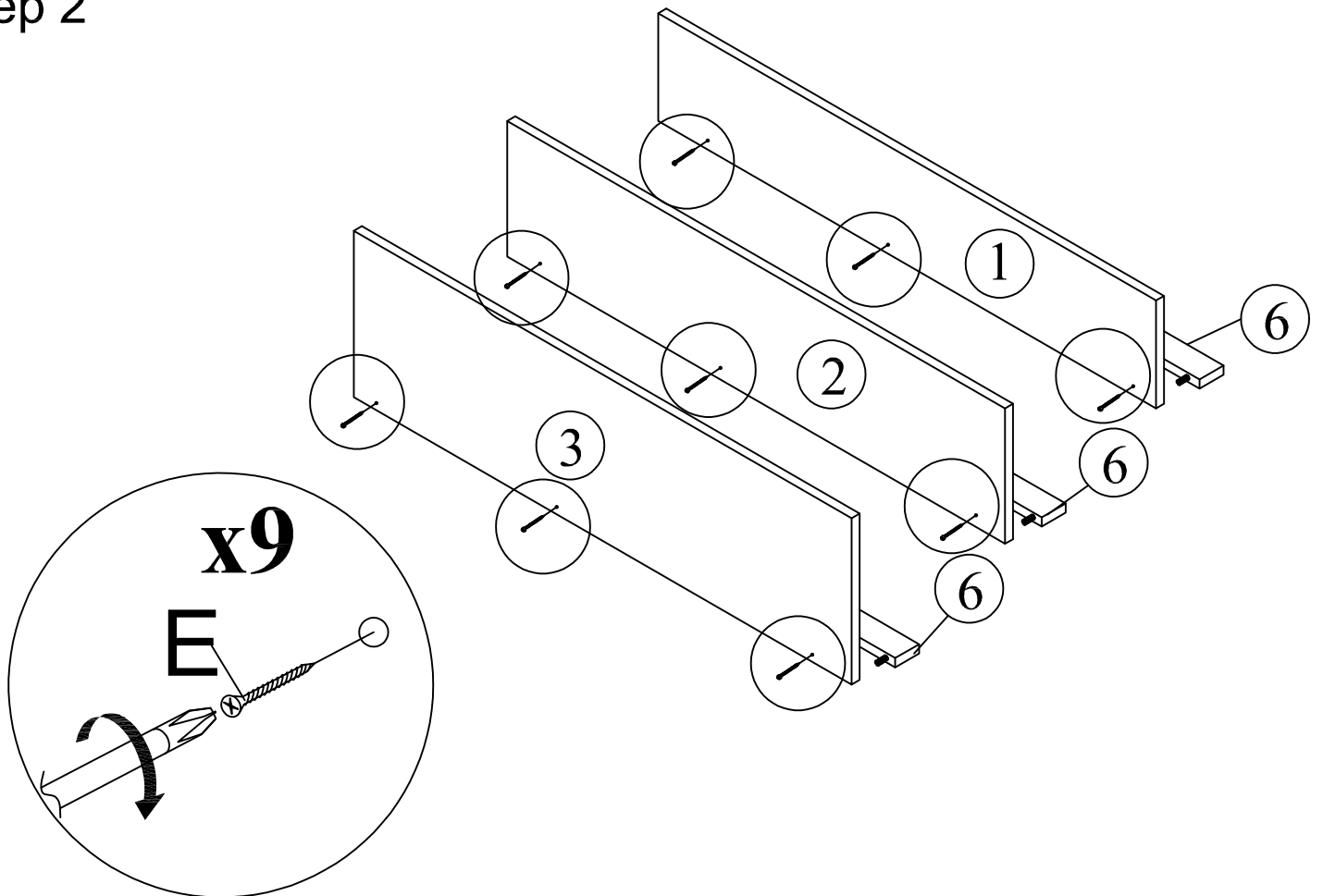

Step 3

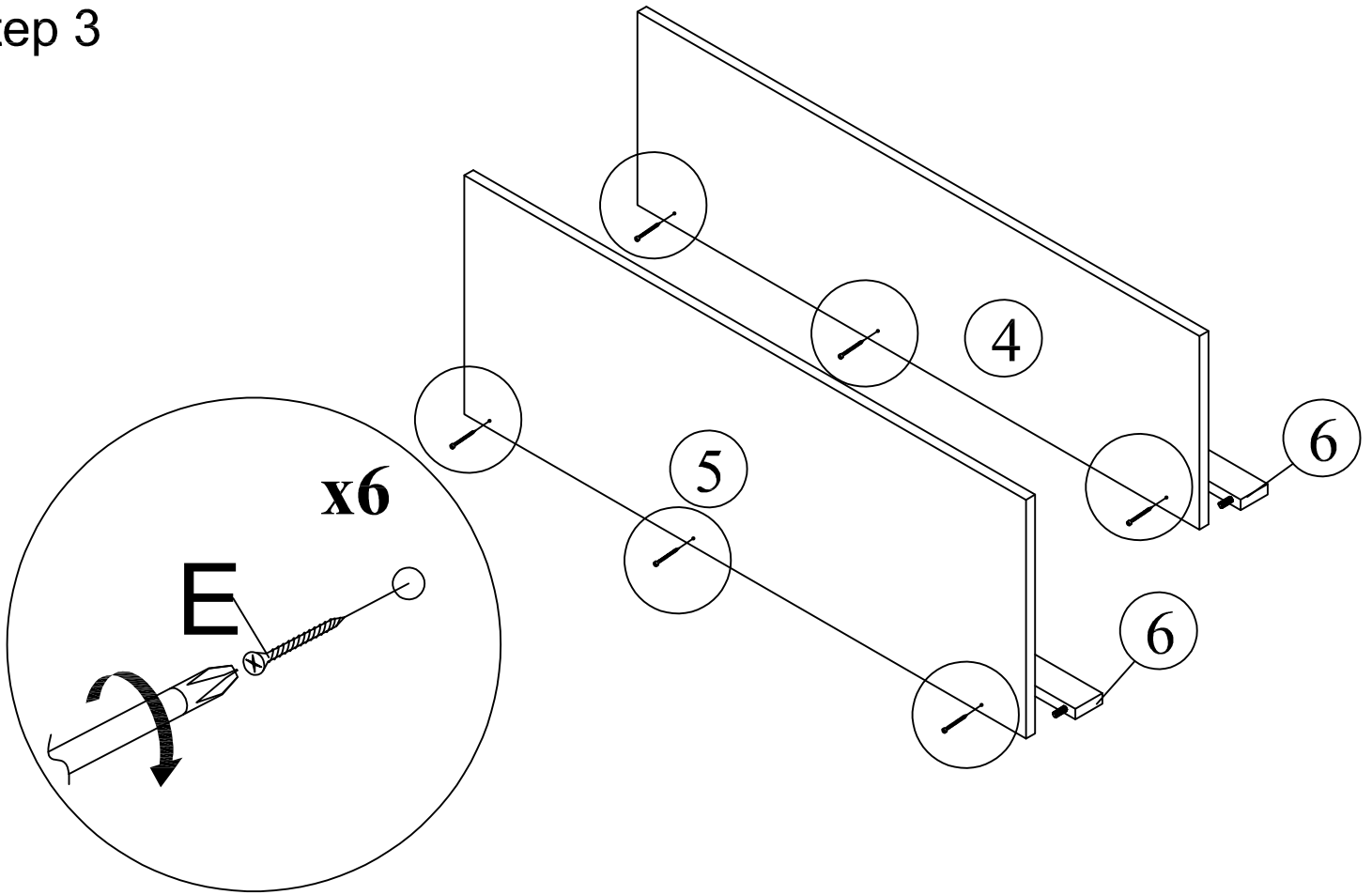

Step 4

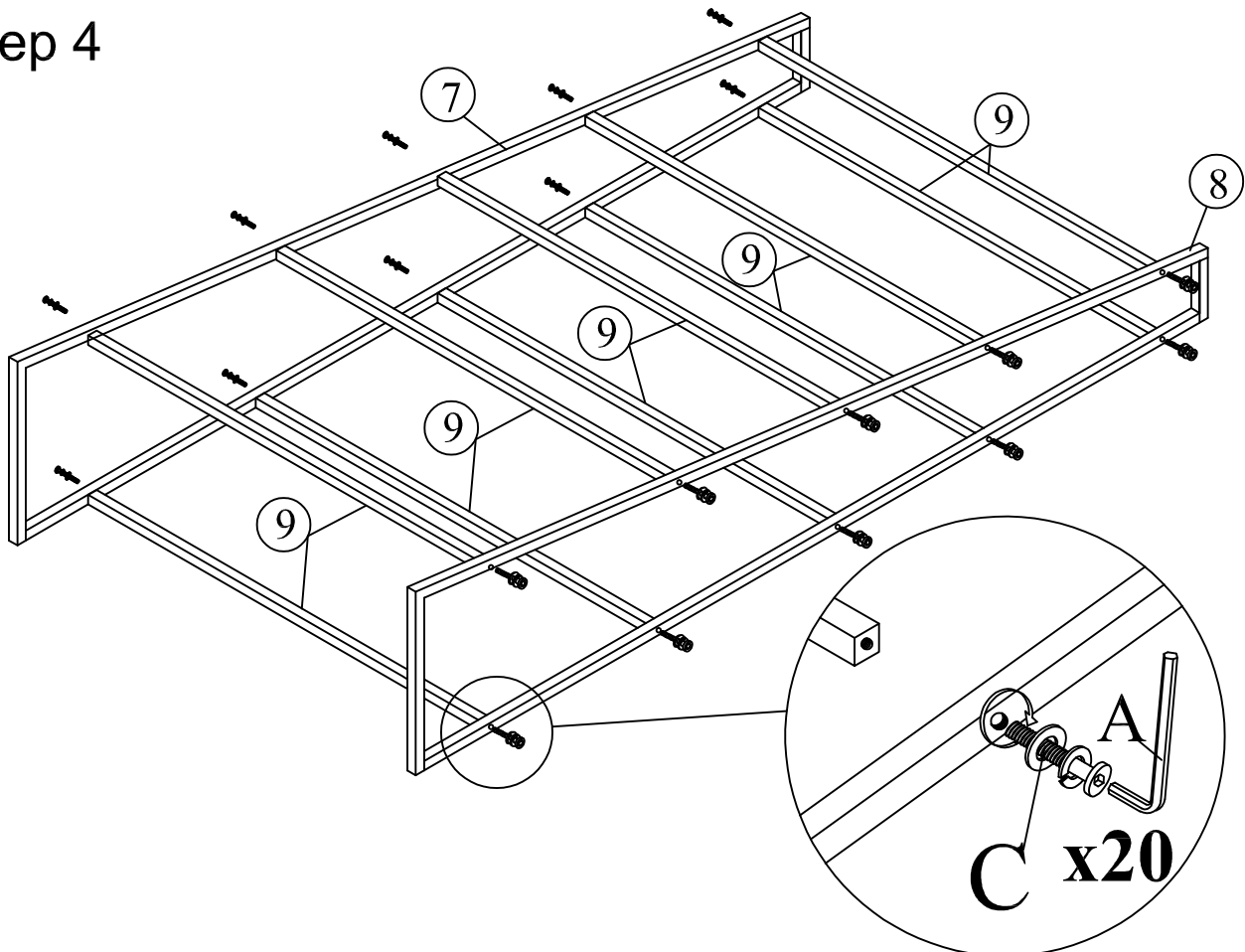

Step 5

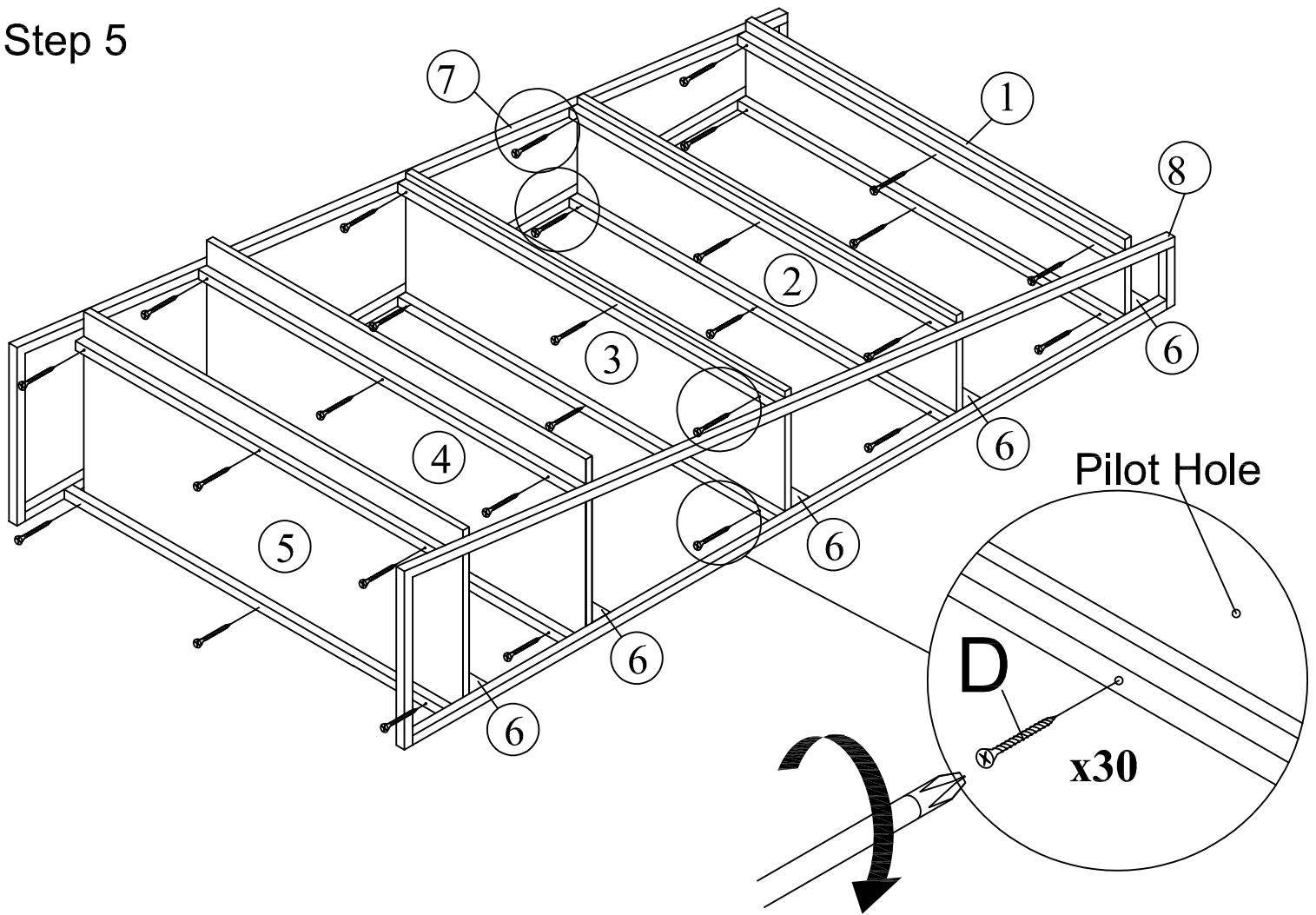

Step 6

